

STH-6230

IR LED Outdoor Camera Housing

- **IR Illuminator range up to 120 m**
- **11 IR LEDs (adjustable power)**
- **Special window heater**
- **Dual heaters inside the housing**
- **IR illuminator activation synchronized with camera switching into B/W mode**
- **IP66 rated**
- **Side opening of the housing**
- **Wall bracket supplied with the housing**
- **Full cable feedthrough**
- **Construction: die-cast aluminium**
- **Integrated sun shield**
- **Built-in 12 VDC power supply (3.5 A)**



The STH-6230D-PSU2 IR LED housing is ideal for providing camera operation (Day/Night and B/W) in a wide temperature range in adverse weather conditions. 11 powerful LEDs are equipped with wide-angle and narrow-angle lenses to provide uniform directional pattern and up to 120 m range (actual illuminator range depends on sensitivity of cameras).

A special output is provided inside the housing for synchronization of the illuminator activation with Day/Night camera switching into B/W mode. Only Day/Night cameras with external Color/BW switching input or B/W cameras are suitable for use with the housing.

Dual built-in heaters are used for heating of the enclosure interior and ensure camera operation at low temperatures (up to -55°C). A special heater integrated into the housing window prevents window fogging and freezing in adverse weather conditions.

Integrated sun shield ensures protection from direct sun light falling on the viewing window and prevents glare. The STH-6230D-PSU2 is suitable for large format cameras, zoom lens cameras, as well as for cameras susceptible to overheating.

The STH-6230D-PSU2 is equipped with a built-in switched camera power supply. Due to use of high-current power supply (3.5 A), the housing allows to install IP cameras and high-power cameras.

Side opening of the housing top provides easy access to camera, allowing to adjust camera position on the mounting plate. The supplied bracket provides for cable feedthrough and allows to hide the cable inside the wall or feed it outside from the bottom of the bracket.

OUTDOOR CAMERA HOUSINGS

Dimensions

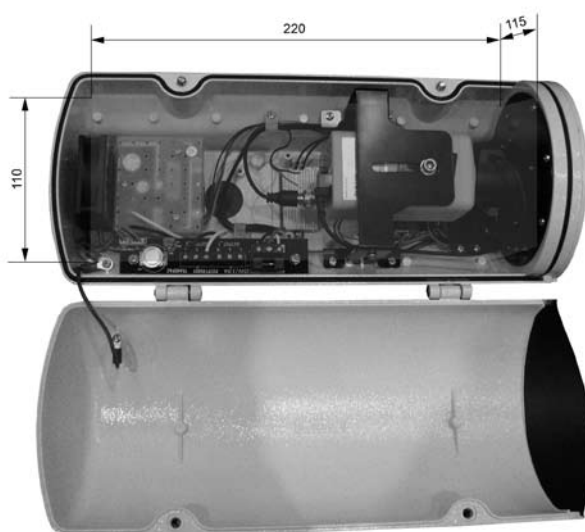

Unit: mm

Specifications

Model:	STH-6230D-PSU2
Number of LEDs:	11
IR Illuminator Range:	Up to 120 m
Illumination Angle:	45°-25°
IP rating:	IP66
Construction:	Die-cast aluminium, ivory powder coat
Number of Heaters:	2+ window heater ('sweating' and freezing prevention)
Internal Heater ON/OFF:	ON at 0°C OFF at +10°C
Window Heater On/OFF:	ON at +18°C OFF at +28°C
Operating Temperature:	-55° to +50°C
Glass Thickness:	4 mm
Built-in Power Supply:	12 VDC, 3.5 A
Input voltage:	220 VAC
Effective Internal Space:	200x110x115 mm
Dimensions:	425x160x165 mm
Weight :	5.23 kg

Accessories

STB-C20	Pole mount adapter for STH-1230, STH-3230, STH-5230 series housings
STB-C21	Corner mount adapter for STH-1230, STH-3230, STH-5230 series housings