



Smartec STC-3904/3902/3905 Day/Night High-Speed Dome Cameras



User Manual

CONTENTS

Warning & Caution	3
What's in the Box	3
General Fratures	4
Names of Each Part	5
Installation	6
A. Connection Method	6
B. Ceiling Mount Type	8
C. Embedded Mount Type	9
D. Pipe Mount Type	10
E. Gooseneck Mount Type	12
F. Wall Mount Type	13
G. Corner Mount Type	14
H. Pole Mount Type	15
I. Indoor Housing Adaptor Type	16
Quick Operating Keys	18
Diagnostic	20
OSD Menu Setting	21
A. OSD Menu Table	21
B. DOME SET	22
C. CAMERA SET	28
D. PRESET	30
E. AUTO SCAN SET	31
F. TOUR SET	32
G. PRIVACY SET	33
H. PATTERN SET	34
I. ALARM SET	35
J. ALARM SET	36
DIP Switch Setting	37
A. ID Setting	37
B. 485 Termination	39
C. Protocol	39
D. Baud Rate Setting	39
Trouble shooting	40
Specification	41
Dimensions	42

WARNING & CAUTION

If you fail to read this information and handle the product incorrectly, death or serious injury may occur.

The unit should be installed by the trained personnel

Switch off immediately if the product emits smoke or abnormal heat.

Never install the product in area exposed oil or gas.

Never install the product on a ceiling that cannot hold its weight.

Never touch the power cord with wet hands.

Clean only with dry cloth.



Never install the product in extreme high or low temperature.

Never drop, hit strongly nor vibrate the product.

Never expose the product to direct sunlight or severe ray.

Never touch the front glass of the product.

Never install the product in areas exposed to rain or water.

	CAUTION RISK OF ELECTRIC SHOCK DO NOT OPEN	
CAUTION: TO REDUCE THE RISK OF ELECTRIC SHOCK, DO NOT REMOVE COVER (OR BACK). NO USER SERVICEABLE PARTS INSIDE. REFER SERVICING TO QUALIFIED SERVICE PERSONNEL.		



This symbol is intended to alert the user to the presence of uninsulated "dangerous voltage" within the product's enclosure that may be of sufficient magnitude to constitute a risk of electric shock to persons.



This symbol is intended to alert the user to the presence of important operating and maintenance (servicing) instructions in the literature accompanying the appliance.

What's in the Box ?

1. Camera
2. Ceiling Mount Bracket
3. Wrench
4. Screw (Ø3x6 screw-----2EA,
Ø4x16 screw-----5EA)
5. Safety Wire
6. Manual
7. Ceiling Cover
8. Cable ties
9. Terminal Block
(2 Pin-----2EA,
3 Pin, 5 Pin, 6 Pin -----1EA)

GENERAL FEATURES

World most silent speed dome camera

Equipped with silent and smooth timing belt and special gear, low-noisy-technology enhances durable quality of the camera by reducing the mechanical vibration. This camera is the perfect match, both indoor and outdoor, for demanding security and monitoring burglars.

0.024° dome system accuracy with 1/8 micro step

With 0.024° technical accuracy, camera provides excellent sensitive and delicate controlling on preset mode by adapting 1/8 micro step and twin gear system

Reliable RAM-Material

The mechanical stabilization improves the durability and long life time of the camera by using reliable materials especially, stepping motor, slip ring, timing belt and power condenser. This camera case is made of fire resisting material that approved UL grade 94 V-0. It is useful for indoor environment concerning about the fire accident

Compensation function: preset position

The function provides absolute preset position even in difficult applications where vibration and strong winds may otherwise affect dome performance.

Slip Ring for long life time (20million rotate ring tested)

Equipped with slip ring is passed by up to 20 millions rotate ring test within 6 months

Power misconnection protection on 485 terminals

This protection function prevents the communication terminal from being out and trouble when power source falsely connects to the RS-485 terminals. Hi speed dome got a patent for power misconnection protection on RS-485 terminal

Filter changeable True Day/Night

Top quality images are assured under day and night conditions due to the true day / night camera with IR cut filter. Low light sensitivity is further increased by the cameras digital slow shutter.

Quick Operation Keys

This camera provides quick function keys to allow control by most keyboards and DVRs that have Pelco protocol support..

Various Surveillance Functions

Auto Scan repeats pan and tilt between two preset positions with different speed and dwell time.

8 Group Tour up to 8 Programmable Group tours available and each group is consisting up to 60 presets step with different speed and dwell time with 16 characters.

165 Preset positions up to 165 programmable preset positions are available with 16 characters

8 Patterns up to 8 programmable user-defined patterns are available with 16 characters and each one is consisting 50 seconds, total 400

8 Sectors up to 8 programmable user-defined sectors are available with 16 characters

24 Privacy Masking Zones up to 24 programmable user-defined privacy masking zones are available with 16 characters (18X, 26X only)

4 Alarm input and 2 relay out up to 4 alarms and 2 relay out available to match with preset, tours, patterns.

300°/S 200°/S on Preset speed

The 360° full pan function moves through a maximum of 350° /sec., enabling you to quickly pinpoint the spot you want to watch. Tilt speed provides through a maximum 250° /sec on preset. On preset mode, the camera is set up to 300° /sec

200° /S Manual speed

This camera provides up to 200° /sec of manual speed and it's adjustable from 100° /sec to 200° /sec

1/4" Sony Ex-View CCD

Equipped with Sony Ex-view HAD CCD technology, these particular cameras provide excellent sensitivity and low smear levels (18X 26X only)

Multiple languages and protocols

To convenience for the customers, this camera provides several languages and protocols including English, Italian, Polish and Pelco D, Pelco P and Ultrak protocol

Intelligent Pan/Tilt Controlling

Pan and tilt speed compensation function linked to zoom position

NAMES OF EACH PART

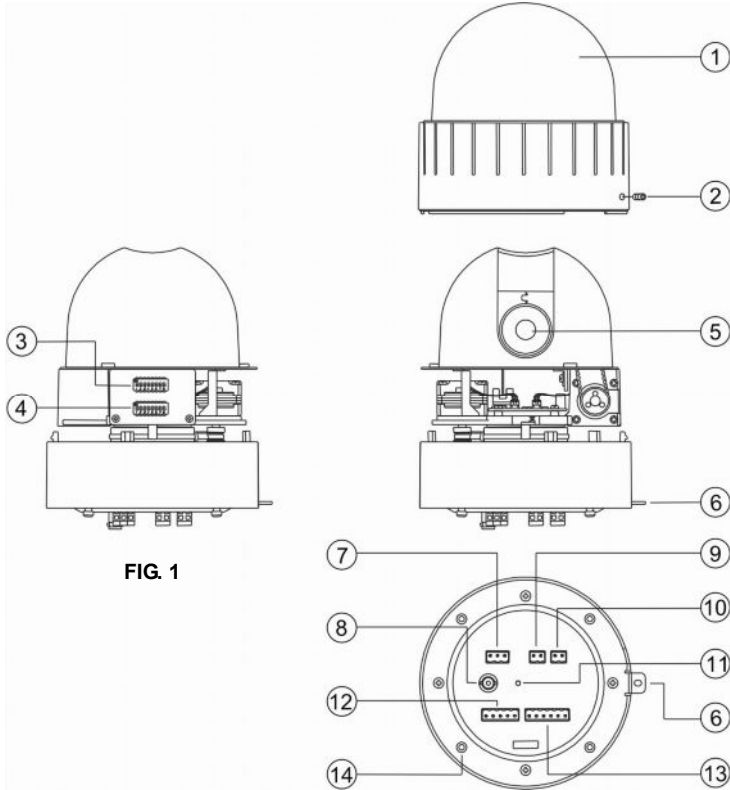
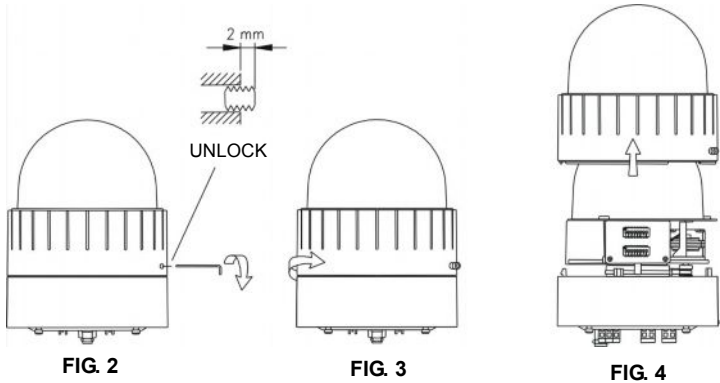

FIG. 1

- | | | | |
|----|--------------|-----|--------------|
| 1. | Bubble | 8. | Video Output |
| 2. | Lock Screw | 9. | Loop RX |
| 3. | DIP Switch 1 | 10. | Loop TX |
| 4. | DIP Switch 2 | 11. | Power LED |
| 5. | Camera | 12. | Aux |
| 6. | Lock Holder | 13. | Alarm |
| 7. | Power | 14. | Mount Holder |

INSTALLATION

A. CONNECTION METHOD



A-1. To separate camera body

Loosen Lock Screw 2mm to the counterclockwise using the wrench.

(Don't pull out the screw) (FIG. 2)

Separate the upper body from the lower body rotating counterclockwise. (FIG. 3, 4)

A-2. After separating, set DIP switches. (Refer to the page 37, 38 and 39)

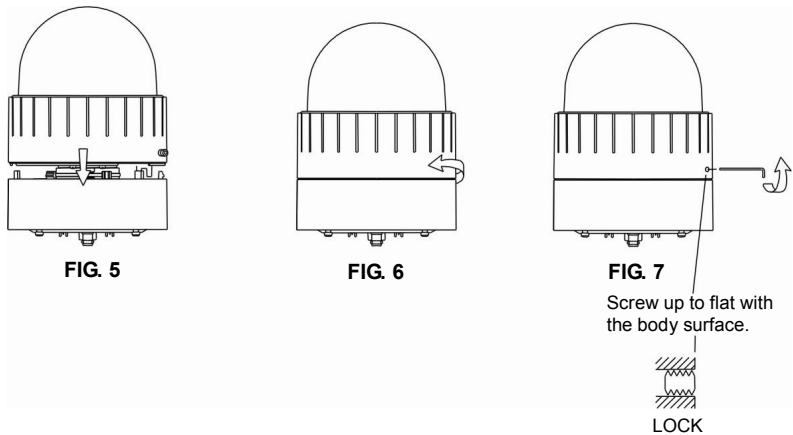

A-3. To assemble camera body

Rotate the upper body clockwise to assemble both bodies (FIG. 5, 6)

Screw up using wrench clockwise. (FIG. 7)

- **Don't screw tightly. It can be the cause of defect.**

INSTALLATION

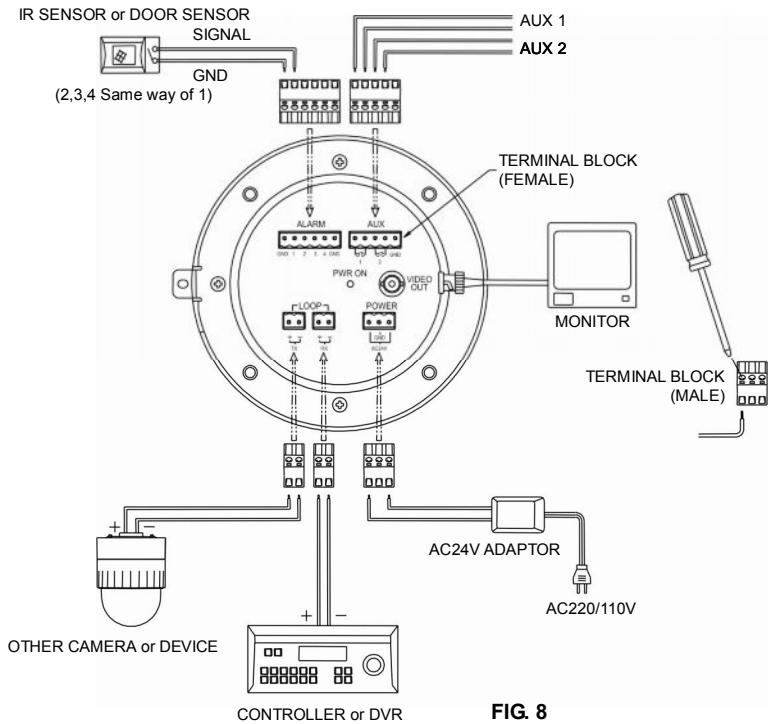

FIG. 8

A-4. Alarm : 4 Alarm input

A-5. AUX : DC 24V 1A can be used as an AUX terminal.

Turning on the light and remote control are possible using AUX.

A-6. TX : TX transmits Data signal received from RX to other equipment.

TX is convenient terminal for connection with Daisy Chain.

A-7. RX : RX are received Control Signal from controller or DVR.

A-8. Video out : BNC connector

A-9. Power : AC 24V 1.0A adaptor

- Don't connect power source to Center terminal of Power.

A-10. Power on LED

INSTALLATION

B. CEILING MOUNT TYPE

CONTENTS

1. CEILING MOUNT BRACKET 1ea

- B-1.** Find the places which are strong enough to support the camera, about 2kg.
B-2. Make a hole, $\text{Ø}145\text{mm}$, on the ceiling. (FIG. 9)
Hook the safety wire to suspension and the safety wire hold on the bracket. (FIG. 10)
B-3. Install the ceiling mount bracket by driving 4 screws, $\text{Ø}4\text{mm}$ tapping screws. (FIG. 11)
B-4. You can make wires simple by cable ties. (FIG. 12)
B-5. Make the wires go through the square hole.
Insert mount holder and twist the camera counterclockwise. (FIG. 13)

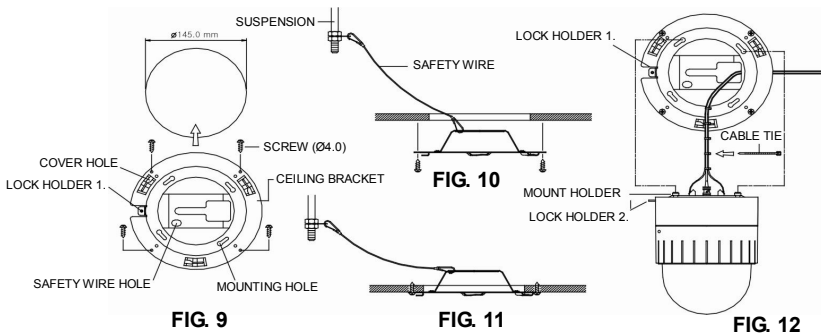

- B-6.** Fix the camera by driving a screw on lock holder1 and 2. (FIG. 14)
B-7. Install the cover by inserting cover lock and twisting clockwise. (FIG. 15)

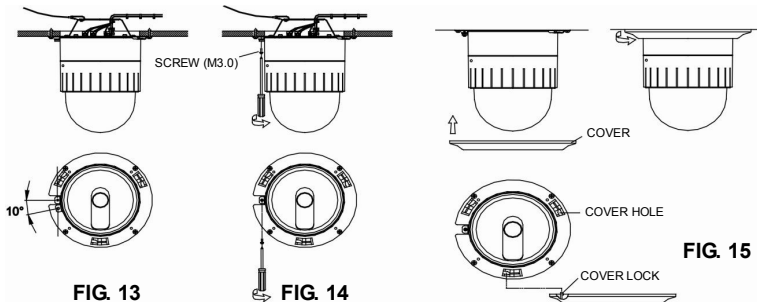

INSTALLATION

C. EMBEDDED MOUNT TYPE

CONTENTS

1. EMBEDDED MOUNT BRACKET 1ea

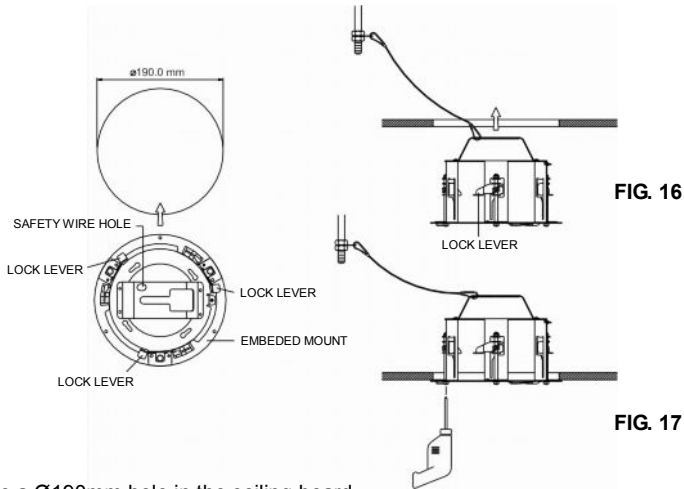

- C-1.** Prepare a $\varnothing 190$ mm hole in the ceiling board.
Fix the safety wire to a suspension to prevent camera from falling.
Other side of safety wire is fixed to the safety wire hole. (FIG. 16)
- C-2.** Fold the Lock Levers then insert the Bracket into the Ceiling Hole.
Fix the Bracket to the ceiling using the driver. (FIG. 17)
- C-3.** Hereafter installation is same way of Ceiling Mount Type. (Refer to the page 8)

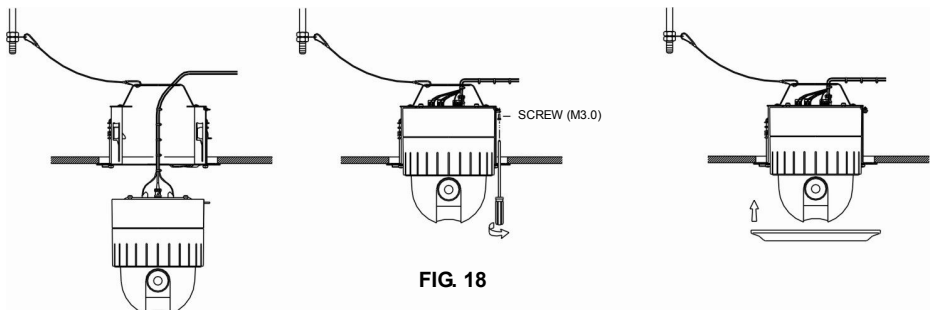

INSTALLATION

D. PIPE MOUNT TYPE

CONTENTS

1. PIPE MOUNT BRACKET 1ea
2. SET ANCHOR BOLT (W5/16) 4ea
3. CAP 1ea

- D-1.** If you want to install the speed dome on the concrete wall, you need to make 12.5mm diameter 4 holes by drill like FIG. 19. (Depth 37mm)
- D-2.** Install SET ANCHOR BOLT on the holes.
- D-3.** Drive a cap on the pipe. (FIG. 20)
- D-4.** After winding the THREAD SEAL TAPE, screw the bracket on the housing. (FIG. 21)
- D-5.** Fix SET ANCHOR BOLT of the bracket by nut.

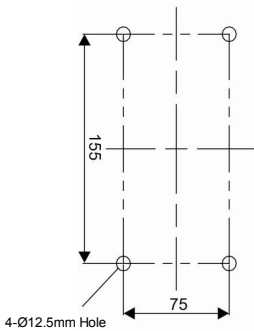

FIG. 19

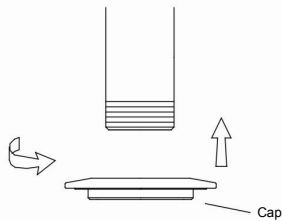

FIG. 20

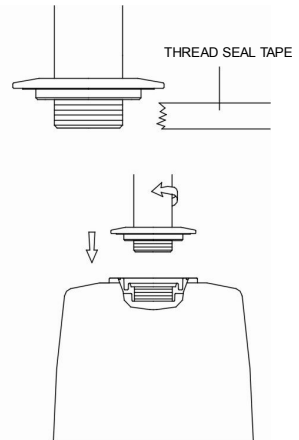
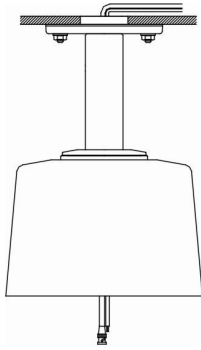
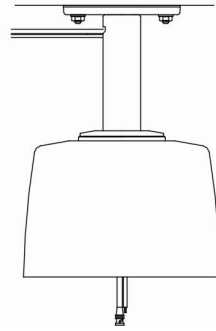

FIG. 21

INSTALLATION



<The cable into ceiling>



<The cable out of ceiling>

FIG. 22

D-6. Tie the wire using the cable ties. (FIG. 23)

D-7. Place the Camera Mount Holder on the Bracket Mount Hole.

To insert them easily, keep 10° interval of Lock Holder1 and Lock Holder2. (FIG. 24)

D-8. Screw up the bubble tightly to prevent water leakage. (FIG. 25)

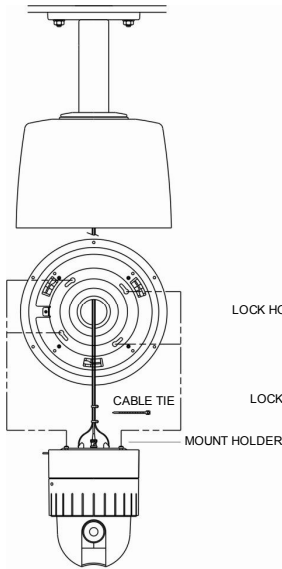

FIG. 23

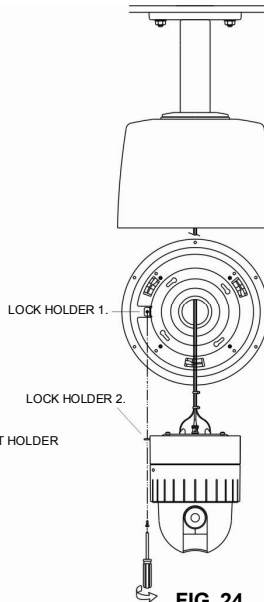

FIG. 24

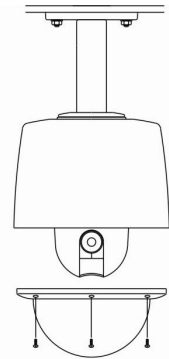

FIG. 25

INSTALLATION

E. GOOSENECK MOUNT TYPE

CONTENTS

1. GOOSENECK MOUNT BRACKET 1ea
2. SET ANCHOR BOLT (W5/16) 4ea
3. CAP 1ea

- E-1.** If you want to install the speed dome on the concrete wall, you need to make 12.5mm diameter 4 holes by drill like FIG. 26. (Depth 37mm)
- E-2.** Install SET ANCHOR BOLT on the holes.
- E-3.** Drive a cap on the pipe. (FIG. 27)
- E-4.** After winding the THREAD SEAL TAPE, screw the bracket on the housing. (FIG. 28)
- E-5.** Fix SET ANCHOR BOLT of the bracket by nut.
- E-6.** Camera installation is the same as that of Pipe mount bracket installation.

(Refer to page 11)

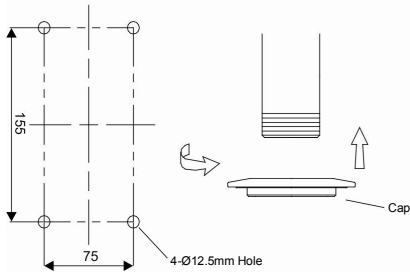

FIG. 26

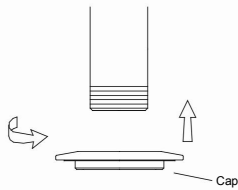

FIG. 27

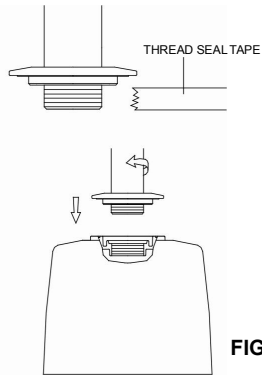
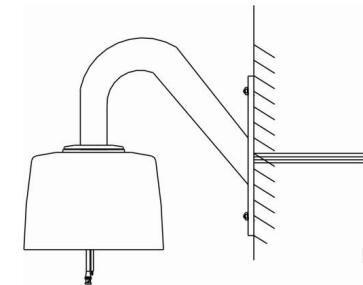
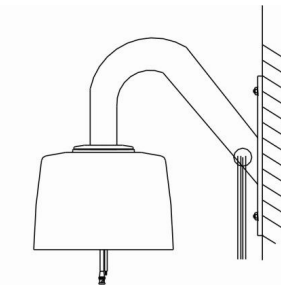

FIG. 28



<The cable into ceiling>

FIG. 29



<The cable out of ceiling>

INSTALLATION

F. WALL MOUNT TYPE

CONTENTS

1. WALL MOUNT BRACKET 1ea
2. SET ANCHOR BOLT (W5/16) 4ea

F-1. If you want to install the speed dome on the concrete wall, you need to make 12.5mm diameter 4 holes by drill like FIG. 30. (Depth 37mm)

F-2. Install SET ANCHOR BOLT on the holes.

F-3. Fix SET ANCHOR BOLT of the bracket by nut.

To install Wall Mount Bracket.

Tip> Select a ceiling board strong enough to hold 4 times the total weight if camera.
(Weight combined camera: approx. 5kg)

F-4. Screw up the Bracket tightly using the wrench(M4.0) after putting the rising into the hole. (FIG. 31)

F-5. Camera installation is the same as that of Pipe mount bracket installation.

(Refer to page 11)

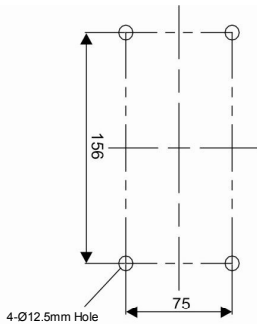

FIG. 30

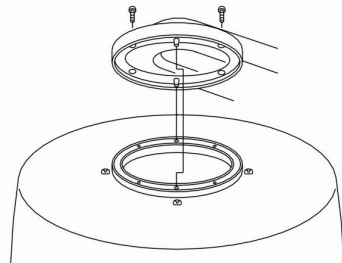
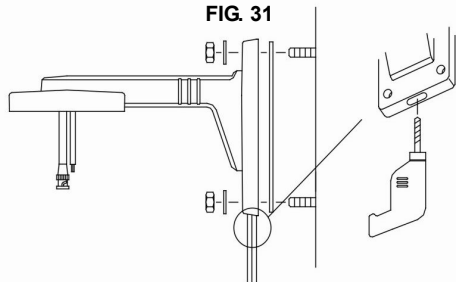
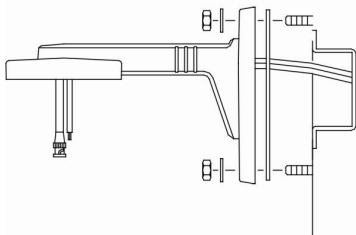

FIG. 31



<The cable out of ceiling>

INSTALLATION

Run the cable into ceiling

G. CORNER MOUNT TYPE

CONTENTS

- | | |
|-----------------------------|--------------------------------|
| 1. CORNER MOUNT BRACKET 1ea | 2. SET ANCHOR BOLT (W5/16) 4ea |
| 3. M10 BOLT & NUT 4ea | |

G-1. First mark the position of holes placing the corner mount bracket.(FIG. 33)

Make $\varnothing 12.5\text{mm}$ 4 holes by drill. (Depth 37mm)

G-2. Install SET ANCHOR BOLT on the holes.

G-3. Fix the wanted bracket (wall mount bracket, gooseneck mount bracket) on the corner mount bracket with 4ea of M10 bolt before you install the corner mount bracket.(FIG. 34)

G-4. Screw the set anchor bolt of the bracket by nut on the wall. (FIG. 35)

G-5. Housing and camera installation is the same as that of Pipe mount bracket installation.

(Refer to page 10, 11)

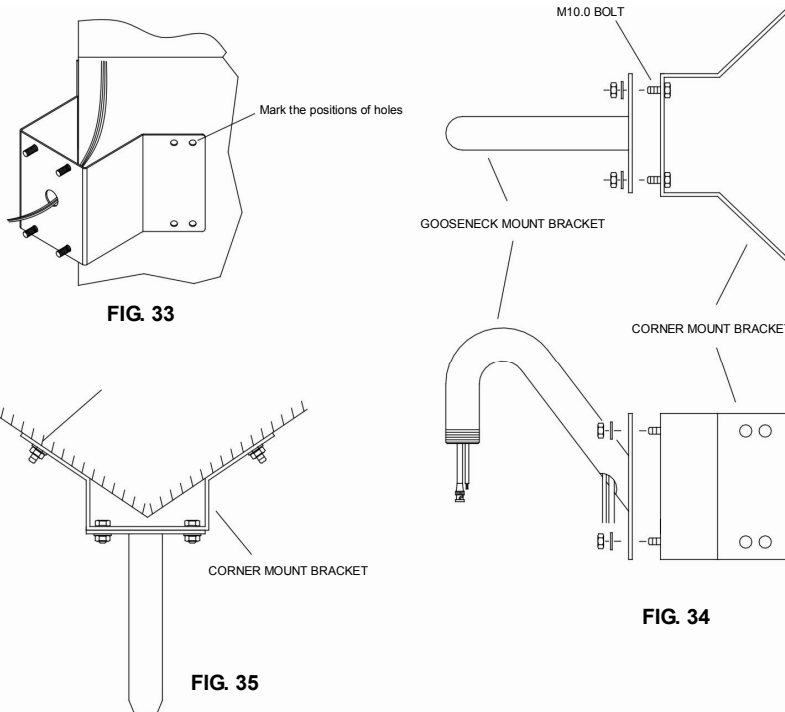

INSTALLATION

H. POLE MOUNT TYPE

CONTENTS

- | | |
|---------------------------|-----------------|
| 1. POLE MOUNT BRACKET 1ea | 2. SUS BAND 2ea |
| 3. M10 BOLT & NUT 4ea | |

H-1. Fix the wanted bracket on the corner mount bracket with 4ea of M10 bolt before you Install the corner mount bracket. (FIG. 36)

H-2. Tie the bracket with sus band tightly. (FIG. 37)

H-3. Housing and camera installation is the same as that of Pipe mount bracket installation.

(Refer to page 10, 11)

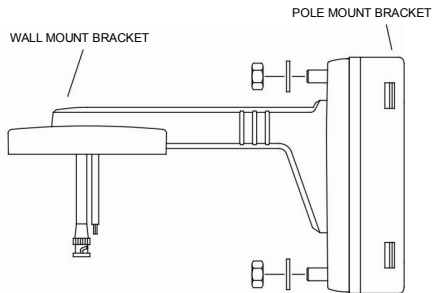
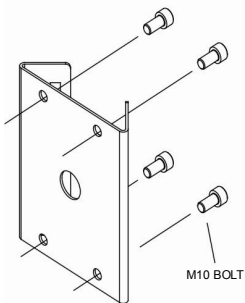

FIG. 36

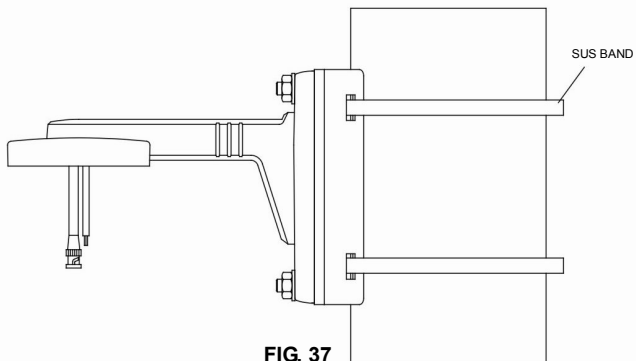

FIG. 37

INSTALLATION

I. INDOOR HOUSING ADAPTOR TYPE

CONTENTS

1. INDOOR HOUSING 1ea
2. PIPE NUT 2ea

- I-1. After screwing pipe nut on the pipe and inserting it into housing, fix the pipe with housing By screwing the nut again. (FIG. 38)
- I-2. Fix the ceiling bracket on the housing by M4.0 screw. (FIG. 39)
- I-3. Tie the wire using the cable tie. (FIG. 39)
- I-4. Let the wires to be put into the square hole. (FIG. 39)
Place the Camera Mount Holder on the Bracket Mount Hole.
To insert them easily, keep 10° interval of Lock Holder1 and Holder 2.

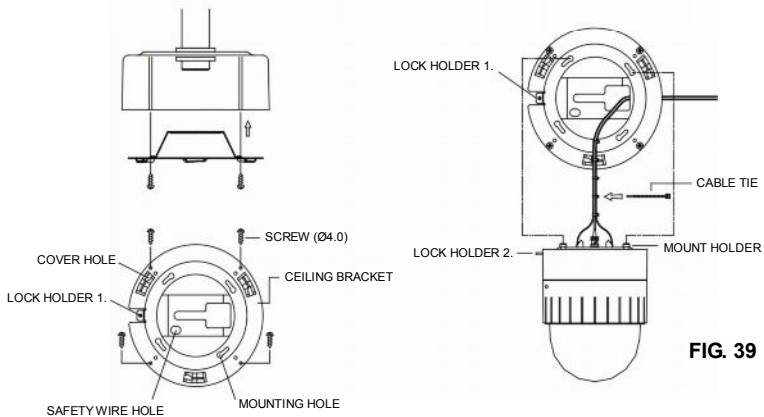
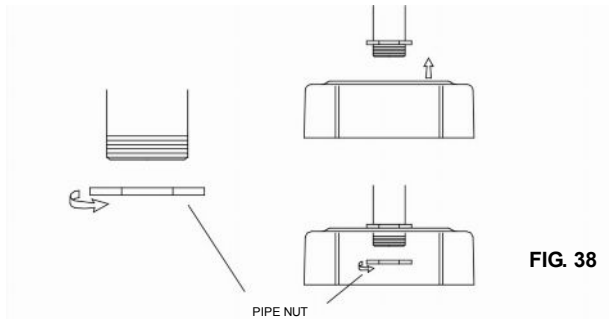

INSTALLATION

- I-5. To assemble, rotate the camera clockwise by 10°. (FIG. 40)
- I-6. Screw up Lock Holders with screws. (FIG. 41)
- I-7. Assemble the cover.
Fix three Cover Locks to three Cover Holes rotating clockwise. (FIG. 42)

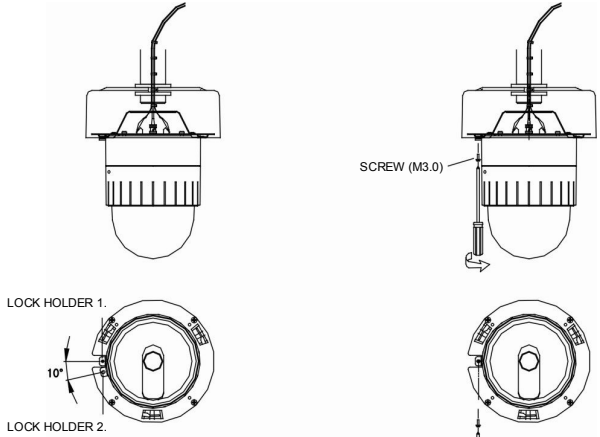

FIG. 40

FIG. 41

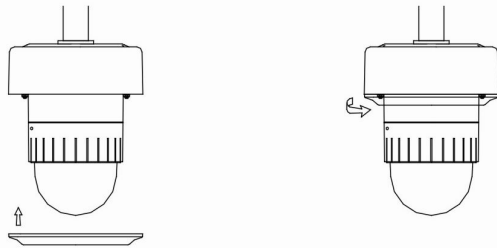

FIG. 42

QUICK OPERATING KEYS

The dome supports Pelco-D/P, SAMSUNG and VICON protocols.

The dome may be used with any controller or DVR etc that supports the Pelco D and Pelco P protocols.

The default setting of the dome is Pelco D / P (auto detection) with 2400 bps (baud rate).

[PELCO D/P PROTOCOLS]

The comprehensive feature set of the dome is available from Pelco compatible controllers via quick operation keys as defined below.

1-64 + preset and 100~200 + preset are used for normal user presets.

Presets 65-99 + are reserved for special functions.

For example, to enter OSD MENU, press the button **95** + **PRESET**

<Quick Operation Key Table 1>

Number	Note	Function
1~64, 100~200 +Preset	Preset	Executing Preset 1 ~ 64, 100~200
65 +Preset	Preset Status	Display Preset Status
66 +Preset	Auto Scan	Executing Auto Scan
67 +Preset	Auto Flip	Selectable On/Off in Auto Flip mode
68 + Preset	Camera Reset	Re-setting Zoom camera module
70 + Preset	VIB CORR	Selectable On/Off in Picture Stabilization function
71~78 + Preset	Group Tour	Executing Group Tour #1 ~ #8
81~88 + Preset	Pattern	Executing Pattern #1 ~ #8
91 + Preset	Zero Position	Searching Pan / Tilt Zero Position
92 + Preset	Freeze	Select Freeze image when camera is working
93 + Preset	BLC	Selectable On/Off in BLC function
94 + Preset	Day / Night	Selectable Day / Night / Auto Mode
95 + Preset	OSD	Entering OSD Main Menu
96 + Preset	Focus Adjust	Focus adjust
97 +Preset	Alarm	Selectable Enable/Disable all Alarms
98 +Preset	AUX 1	Selectable On/Off in Aux1
99 +Preset	AUX 2	Selectable On/Off in Aux2

<Quick Operation Keys Table 2: Use these function keys if controller has these keys>

Menu	Function
Tilt Up / Down	Sub menu cursor moves up / down
Pan Left / Right	Enter to the sub menu or status change or decrement
Focus Near	Using for Enter key when user select YES or NO
Focus Far	Using for function changing keys when set coordinate
Zoom Tele	Status cursor to the right
Zoom Wide	Status cursor to the left

- **65 + preset** : "Preset Status" is displayed, to remove this screen, press **Focus Near** button.
- **70 + preset** : This feature provides picture stabilization image and it is by EX980S (P) module only.

This feature is operating by preset number but not included in OSD main menu.

This is optional function due to zoom module

QUICK OPERATING KEYS

- **[92 + preset]** : This feature freezes the current live image during tour, auto scan or pattern operation. When you press **[92 + preset]** button, the image freezes but the camera is still working as per operation such as tour, pattern or auto scan. To return to normal images, press **[92 + preset]** button again.
This feature is operated by preset number but not included in OSD main menu.
- Due to Zoom camera module, OSD Menu not provides every feature. In this case, "Not available" is displayed on the monitor.

[MAXPRO PROTOCOL]

If user wants to choose Maxpro Protocol, the user may change the dip switch first.

(Refer to Page #32 DIP SWITCH SETTING - PROTOCOL)

Baud Rate: 9600 (Maxpro default)

Maxpro protocol is almost same as Pelco D/P protocol operating system but some special features are different way as noted below

<Quick Operation Key Table 1>

Number	Note	Function
1~64,100~200 +Preset	Preset	Executing Preset 1 ~ 64, 100~200
67 +Preset	Auto Flip	Selectable On/Off in Auto Flip mode
80~85 + Preset	Pattern	Executing Pattern #1 ~ #6
86 + Preset	Auto Scan	Executing Auto Scan
87~89 + Preset	Group Tour	Executing Group Tour #1 ~ #3
90 + Preset	OSD	Entering OSD Main Menu
91 + Preset	Zero Position	Searching Pan / Tilt Zero Position
92 + Preset	Freeze	Select Freeze image when camera is working
93 + Preset	BLC	Selectable On/Off in BLC function
94 + Preset	Day / Night	Selectable Day / Night / Auto Mode
95 + Preset	OSD	Entering OSD Main Menu
96 + Preset	Focus Adjust	Focus adjust
97 +Preset	Vir. Corr.	Selectable On/Off in Vibration Correction function
98 +Preset	AUX 1	Selectable On/Off in Aux1
99 +Preset	AUX 2	Selectable On/Off in Aux2

<Quick Operation Keys Table 2: Use these function keys if controller has these keys>

Menu	Function
Tilt Up / Down	Sub menu cursor moves up / down
Pan Left / Right	Enter to the sub menu or status change or decrement
Focus Near	Using for Enter key when user select YES or NO
Focus Far	Using for function changing keys when set coordinate
Zoom Tele	Status cursor to the right
Zoom Wide	Status cursor to the left

- Due to Zoom camera module, OSD Menu provides not every feature. In this case, "Not available" is displayed on the monitor.

DIAGNOSTIC

Whenever the dome is powered on, a standard diagnostic is operated.

CAMERA ID : 001

BAUD RATE : 2400 BPS

WAITING.....

PAN ORIGIN TEST OK

TILT ORIGIN TEST OK

TX CONNECTION TEST OK

CAMERA COMM TEST OK

- A. Pan Origin Test
Zero point of Pan is located during the Panning test.
- B. Tilt Origin Test
Zero point of Tilt is located during the Tilt test.
- C. TX connection Test
Wait for 60 seconds for TX Connection Test,
During 60 seconds, the camera is must received a signal by any control equipment as DVR or controller.
Then Ok is displayed then automatically verifying TX Connection Test.
* If "Not Tested" is displayed in the test,
 - The result which is not received any signal from DVR or controller
 - Wrong connecting way such as the protocol, baud rate or RS-485 connection.
The use may check the install way carefully.
- D. Camera Comm. Test
Camera communication is also checked.
OK should be displayed in these four tests before installation.

If all the above Tests are OK, "NOW EEPROM CHECKING" and "ALL DATA INITIALIZING" is displayed and the camera is ready to operate.

OSD MENU SETTING

A. OSD MENU TABLE

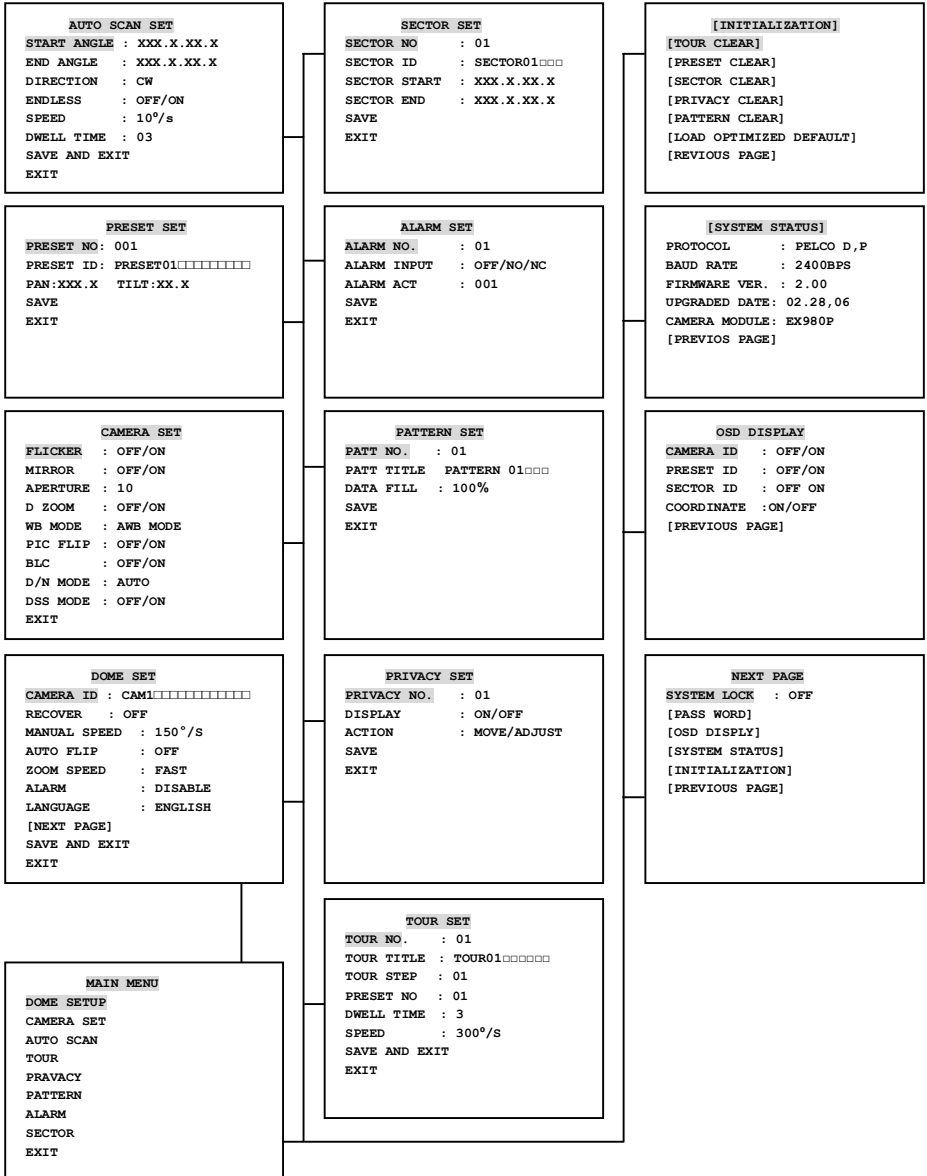

OSD MENU SETTING

To enter OSD Menu, press the button **95+Preset** (Maxpro 90+Preset) then OSD Main Menu is displayed.

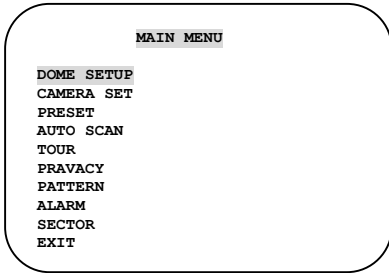

- Use the joystick up down to move the position and left right to make selection.

B. DOME SET

To enter Dome setup, use the joystick right to move when cursor on dome setup.

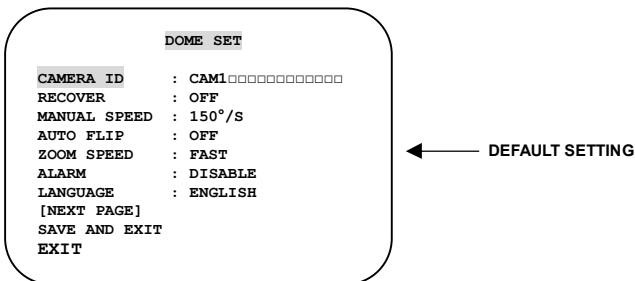

B-1. DOME SET - CAMERA ID

To set camera name, and select a title of up to 16 characters using left or right direction keys or joystick. Press **ZOOM TELE** button to move to the next character from left to right direction and **ZOOM WIDE** button to move to the next character from right to left direction. (Space displays when Appears)

OSD MENU SETTING

B-2. DOME SET - RECOVER

This feature allows the dome to revert to a specific programmed action when the dome has not received a command for the recovery timer period.

Actions can be Auto scan, group tour, preset, and pattern. The recover time can be programmed from 15 second to 90 seconds. The default setting is OFF.

B-3. DOME SET - MANUAL SPEED

Manual Speed of Pan/Tilt is selectable from 100°/sec up to 200 ° /sec.

The default setting is 150°/sec.

B-4. DOME SET - AUTO FLIP

Auto Flip is available and the default setting is OFF. Move joystick right or left direction is for selecting OFF or ON. The default setting is OFF.

This feature is working as [67 + preset] button.

B-5. DOME SET - ZOOM SPEED

Zoom speeds are selectable FAST or SLOW mode. Move joystick to the right direction for selecting FAST or SLOW. The default setting is FAST.

B-6. DOME SET - ALARM

You must enable the alarms for them to operate. The default setting is DISABLED.

This function can be recalled by pushing [97 + preset] button.

B-7. DOME SET - LANGUAGE

Multiple languages are selectable here including English, Italian and Polish.

Move joystick to the right or left direction to select language.

The default setting is ENGLISH.

B-8. DOME SET - [NEXT PAGE]

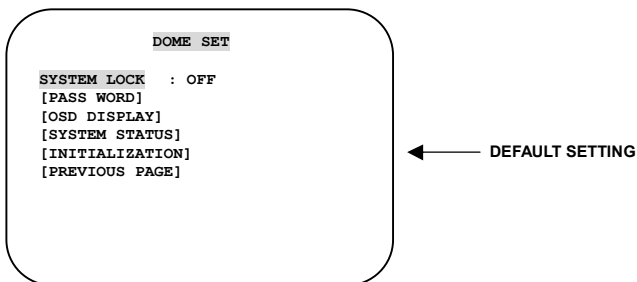

B-8-1. DOME SET - [NEXT PAGE] - SYSTEM LOCK

All stored dome settings can be password protected to prevent unauthorized changes.

In order to enter [PASS WORD] page, the system lock status must firstly be set as ON.

The default setting is OFF.

OSD MENU SETTING

B-8-2. DOME SET - [NEXT PAGE] – [PASSWORD]

To enter this page to set a password, move joystick or pan key in the right direction.
The password must be set by preset number from 001 to 255 (Default 99)

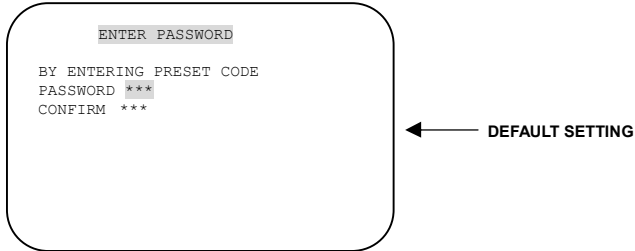

Enter any number from 001~255 on the password blank area and again on the confirm blank area. Then "CONFIRMED" is displayed on the monitor and the menu will go back to the previous page automatically.

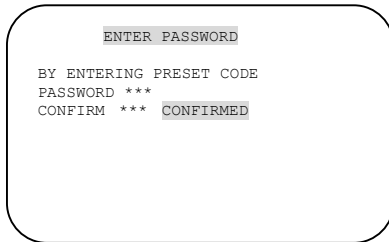

<CONFIRMED>

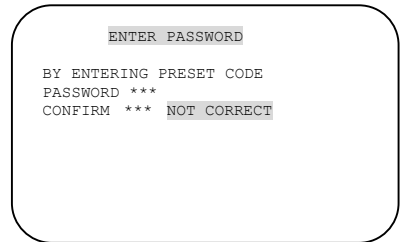

<CANCELLED>

If you press an incorrect number between PASSWORD and CONFIRM, "CANCELLED" is displayed on the monitor when you press FOCUS FAR key, "CANCELLED" will be displayed on the monitor, it goes to previous page.

- * When a password has been set, the operator must enter the correct password in order to enter OSD MAIN MENU, or to change any of the domes configuration data.
- * If you set a password you must ensure that it does not get lost. If this happens the dome must be returned for workshop repair.

OSD MENU SETTING

B-8-3. DOME SET - [NEXT PAGE] - [OSD DISPLAY]

The camera ID setting defines whether the camera OSD display is displayed or switched off.

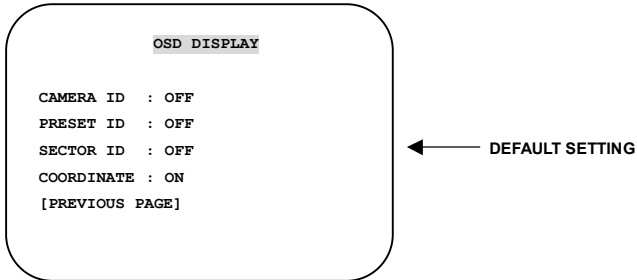

B-8-4. DOME SET - [NEXT PAGE] - [SYSTEM STATUS]

This page shows the information of this camera.

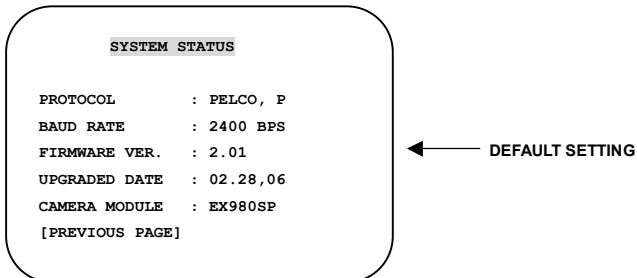

- Protocol and baud rate are shown due to the dip switch setting (Refer to page 30, 31 and 32)
- Firmware version and upgraded date will change if upgraded.
- Camera module is settling as follows
 - * 18X : SONY ZOOM MODULE # EX480C
 - * 26X : SONY ZOOM MODULE # EX980C / EX980CS
 - * 23X : SAMSUNG ZOOM MODULE # SDM231
 - * 30X : SAMSUNG ZOOM MODULE # SDM300
 - * 36X : SONY ZOOM MODULE # Ex1000 OR EX1010

OSD MENU SETTING

B-8-5. DOME SET - [NEXT PAGE] - [INITIALIZATION]

To clear the current settings select the item that you wish to reset back to factory defaults.

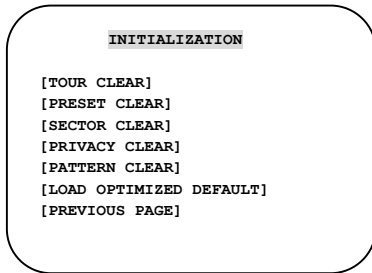

- To clear the memorized data, move the joystick or pan right key until the cursor is on the required item.

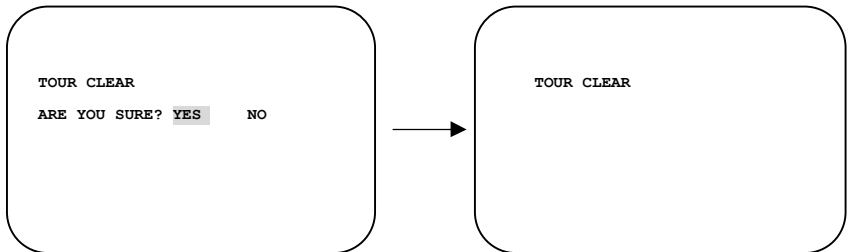

Press **FOCUS NEAR** button when the cursor is at YES in order to clear memorized data. Then each item such as tour, preset, and sector will flicker for about 2~3 seconds. After this process, the menu is returned to the previous page.

* Use the above method for [PRESET CLEAR], [SECTOR CLEAR],[PRIVACY CLEAR], [PATTERN CLEAR], [TOUR CLEAR].

OSD MENU SETTING



- To clear all data and return to factory defaults, move the joystick right or press the pan right key to when the cursor is at [LOAD OPTIMIZED DEFAULT] to enter the next page.
- Move joystick or the pan right key so that the cursor is over YES, then press the FOCUS NEAR button.
“ALL DATA INITIALIZING” is then displayed for about 5~7 seconds and then the menu is returned to the previous page automatically.

B-9. DOME SET - [NEXT PAGE] - SAVE AND EXIT

To saving the memorized data and escape this page, move joystick to the right direction when cursor is at SAVE AND EXIT.

B-10. DOME SET - [NEXT PAGE] - EXIT

In order not to save any data and wants to escape this page, move joystick to the right direction when cursor is at EXIT.

OSD MENU SETTING

C. CAMERA SET

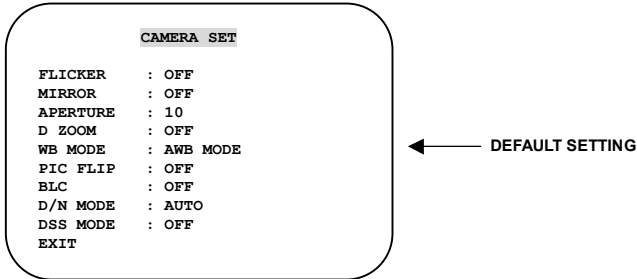

C-1. CAMERA SET - FLICKERLESS

The flickerless feature has options of 50Hz and 60Hz. The default setting is OFF (NTSC: 60Hz / PAL: 50Hz). The flickerless mode only needs to be set when there is a mismatch between the power frequency and camera sync rate.

The default setting is OFF.

C-2. CAMERA SET - MIRROR

This feature literally swaps the image left and right as if looking into a mirror.

The default setting is OFF.

C-3. CAMERA SET - APERTURE

Aperture correction enhances the picture details and sharpness by increasing the gain of the camera. Increase the value to sharpen the image, decrease to soften it The default setting is 10. (the aperture level is from 01 ~ 15)

C-4. CAMERA SET - D ZOOM

If neabled digital zoom is applied when the zoom lens has reached its maximum Optical zoom in capability The default setting is OFF.

C-5. CAMERA SET - WB MODE

White balance functions has 4 modes and may need to be changed depending On the situation.

- * AWB Mode 3,200°K to 6, 000°K (Default)
- * Indoor up to 3,200°K
- * Outdoor up to 5,80°oK
- * ATW Mode - 2,000°K to 10, 000°K

OSD MENU SETTING

C-6. CAMERA SET - PIC FLIP

The picture flip feature swps the top and bottom of the image, literally inverting it.

The default setting is OFF.

C-7. CAMERA SET - BLC (Back Light Compensation)

The default setting is OFF and BLC modes can be OFF/ON.

* OFF Backlight compensation is not activated.

* ON Back light compensation is activated.

This function can be recalled by pushing **93 + preset** button.

C-8. CAMERA SET - D/N MODE

The dome camera can operate in day /night mode and will switch depending on lighting conditions. Alternatively it can be forced into color only mode.

The default setting is AUTO MODE. This function can be recalled by pushing

94 + preset button.

C-9. CAMERA SET - DSS MODE (DIGITAL SLOW SHUTTER)

If digital slow shutter is enabled the exposure time of the camera is increased, this allowing more light to be collected and improving low light response. This setting should not be enabled if the dome is touring at night or fast moving objects are likely to be in the scene as smearing is also increased.

The default setting is OFF.

C-10. CAMERA SET - EXIT

To escape this page, move the joystick right or press the pan right key.

OSD MENU SETTING

D. PRESET SET

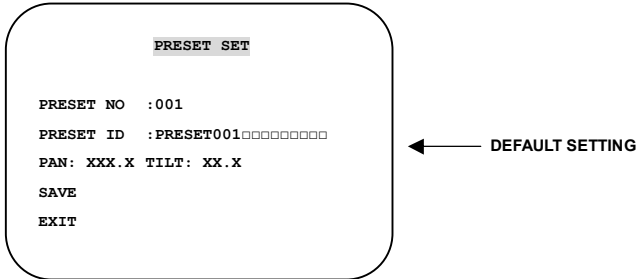

D-1. PRESET - PRESET NO.

Up to 165 preset positions are available.

Use the joystick or pan left/right keys to select the number.

D-2. PRESET - PRESET ID

To create preset titles use the joystick or pan left/right keys to navigate the menu.

The **ZOOM TELE** button moves to the next character from left to right and

ZOOM WIDE button moves to the next character from right to left

(Space displays when Appears)

D-3. PRESET - PAN: XXX.X TILT: XX.X

Press **FOCUS FAR** button in order to set preset position then, use the joystick or pan left/right keys to the position where memorized preset number .is needed.

Then press **FOCUS FAR** button again after setting a preset location.

D-4. PRESET - SAVE

Move the joystick right or press the pan right key when the cursor is at SAVE and then the cursor will be located on Preset ID for the continuous preset No. setting.

D-5. PRESET - EXIT

To escape this page, move joystick to the right direction.

OSD MENU SETTING

E. AUTO SCAN SET

- **66 + preset** (Maxpro: 86+Preset) button is working as AUTO SCAN after setting.

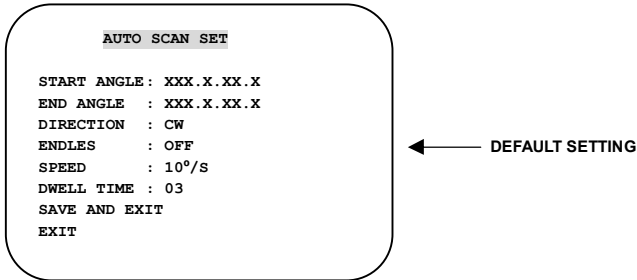

E-1. AUTO SCAN - START ANGLE

To set the start position, press **FOCUS FAR** button then move the dome to the required start position. Press **FOCUS FAR** button again is to escape.

E-2. AUTO SCAN - END ANGLE

To set the end position, press **FOCUS FAR** button then move the dome to the required end position. Press **FOCUS FAR** button again is to escape.

E-3. AUTO SCAN - DIRECTION

Auto Scan directions are available as CW or CCW.

- * CW: Clock wise direction (Default)
- * CCW: Count Clock Wise Direction.

E-4. AUTO SCAN - ENDLESS

Auto Scan can be set to endless rotation by enabling the endless option.

The default setting is OFF.

E-5. AUTO SCAN - SPEED

The scan speed can be programmed from 05°/S up to 35°/S.

The default setting is 10°/S.

E-6. AUTO SCAN - DWELL TIME

The dwell time at the start and end points can be programmed from 1 second to 30 seconds. The default setting is 03 seconds.

E-7. AUTO SCAN - SAVE AND EXIT

To save the memorized data and escape this page, move the joystick right or press the pan right key when the cursor is at SAVE AND EXIT.

E-8. AUTO SCAN - EXIT

To escape this page, move joystick to the right direction.

OSD MENU SETTING

F. TOUR SET

8 Programmable tours can be set and each tour can have up to 64 preset steps.

After setting up the tours the 71~78 + preset buttons launch group tours # 1~8.

- Maxpro protocol provides three (3) quick operation keys (87~89 + preset) for Group tour but it is possible to set up to Group tour #8.

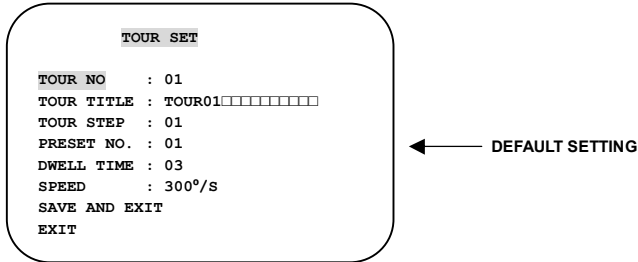

F-1. TOUR SET - TOUR NO.

Up to 8 group tours can be programmed.

F-2. TOUR SET - TOUR TITLE

To set a tour title, use the joystick left/right or pan left/right keys. Each title can have up to 16 characters. Press **ZOOM TELE** button to move the next character from left to the right and **ZOOM WIDE** button to move the next character from right to left (Space displays when □ appears) The tour title is not displayed on the monitor and is only for the reference of user.

F-3. TOUR SET - TOUR STEP

Each tour group consists of up to 60 preset steps with different dwell time and speed. It is possible to match any preset # for any tour step.

F-4. TOUR SET - PRESET NO.

For each tour step it is possible to select any preset number up to 64.

The default setting is BLK

F-5. TOUR SET - DWELL TIME

Dwell time can be programmed from 1-99 seconds. The default setting is 03 seconds.

F-6. TOUR SET - SPEED

Each tour step can be set with a different speed up to 200°/S and it is selectable from 10°/S. The default setting is 200°/S.

F-7. TOUR SET - SAVE

To save the memorized data and escape this page, move the joystick right or press the pan right key when cursor is at SAVE

F-8. TOUR SET - EXIT

To escape this page, move joystick to the right direction

OSD MENU SETTING

G. PRIVACY SET

24 Privacy masking zones can be set.

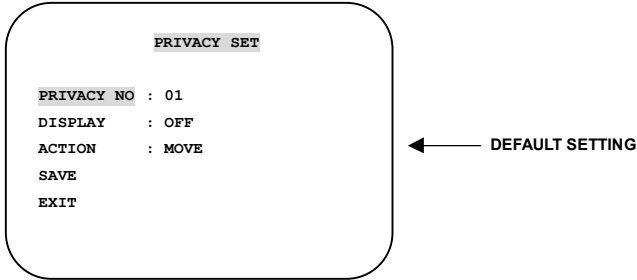

G-1. PRIVACY SET - PRIVACY NO.

Up to 4 privacy masking zones can be set.

G-2. PRIVACY SET - DISPLAY

Move the joystick right or left or press pan right/left to set ON in order to show the selectable block in the center of the monitor. This block appears as a translucent square with blue colour when set ON. The default setting is OFF.

G-3. PRIVACY SET - ACTION (MOVE / ADJUST)

To set the blocking area, press **FOCUS FAR** button when MOVE MODE is displayed. Then use the joystick or pan keys to the user defined area in order to set the blocking area. Then press **FOCUS FAR** button again to escape from MOVE MODE.

To adjust the size of the blocking area, move the joystick or use the pan keys when the cursor is on ACTION. After it has changed to ADJUST MODE, press **FOCUS FAR** button in order to adjust the size of the blocking area. The size of the blocking area can be adjusted by using joystick up/down or left right ? or the pan and tilt keys.

After adjusting the size of the blocking area, press **FOCUS FAR** button to escape the ADJUST mode.

* ADJUST: You can change the masking size by using the joystick or pan keys

* MOVE: You can move the masking area by using the joystick or pan keys (Default)

G-4. PRIVACY SET - SAVE

After setting the privacy masking zone, to save the data, move the joystick right or pan right key when the cursor is on SAVE. After saving the data, the cursor moves to PRIVACY NO.2 automatically to prepare for the next privacy masking zone.

G-5. PRIVACY SET - EXIT

To escape this page, move the joystick right.

OSD MENU SETTING

H. PATTERN SET

8 programmable patterns are available with 16 characters of title.

After set the data to the each pattern # 1~8, **[81~88+ preset]** buttons are working as Pattern # 1~8.

- Maxpro protocol provides six (6) quick operation keys (80~85 + preset) for patterns but it is possible to set up to pattern #8.

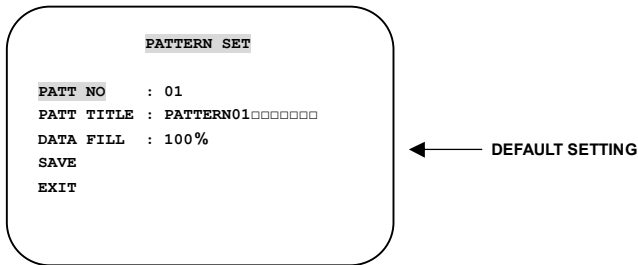

H-1. PATTERN SET - PATT NO.

Up to 8 programmable user-defined patterns are available.

H-2. PATTERN SET - PATT TITLE

To set PATTERN TITLE move Joystick left/right or use the pan keys.

Press **[ZOOM TELE]** button moves to the next character from the left / right and **[ZOOM WIDE]** button moves to the next character from the right / left (Space displays when □ appears) The pattern title is not displayed on the monitor, but only for the reference of the user.

H-3. PATTERN SET - DATA FILL

To memorize a pattern, press **[FOCUS FAR]** button in order to start the process. The progress is shown as % filled. Press **[FOCUS FAR]** button again in order to escape.

H-4. PATTERN SET - SAVE

To save the memorized pattern data, move the joystick right or press the pan right key when the cursor is on SAVE. Then the cursor moves to the PATT NO.02 in order to prepare for the next pattern.

H-5. PATTERN SET - EXIT

To escape this page, move the joystick right or press the pan right key.

OSD MENU SETTING

I. ALARM SET

4 Alarm inputs are available and each alarm is activating to presets, group tours or patterns.



I-1. ALARM SET - ALARM NO.

Up to 4 alarms are selectable by using joystick right or pressing the pan right key when the cursor is on ALARM NO.

I-2. ALARM SET - ALARM INPUT

Alarm inputs can be programmed as NC (Normally Close) or NO (Normally Open)
The default setting is OFF

I-3. ALARM SET - ALARM ACT

Active alarms can trigger modes such as presets, Group tours 1-8, and Patterns 1-8.
Use the joystick or pan keys to select any preset number, group tour no. or pattern no.

I-4. ALARM SET - SAVE

After setting up the alarm features, to save the data move the joystick right or press the pan right key when the cursor is on SAVE. After saving the data, the cursor moves to Alarm NO.2 automatically to prepare for the next alarm.

I-5. ALARM SET - EXIT

To escape this page, move the joystick right or press the pan right key.

* Before activating Alarms, you must set ALARM ENABLE at DOME SET ALARM ENABLE (Refer to page 23)

OSD MENU SETTING

J. SECTOR SET

Up to 8 programmable sectors are available with 16 characters.

This feature is useful to memory the certain location such as parking zone or so on.

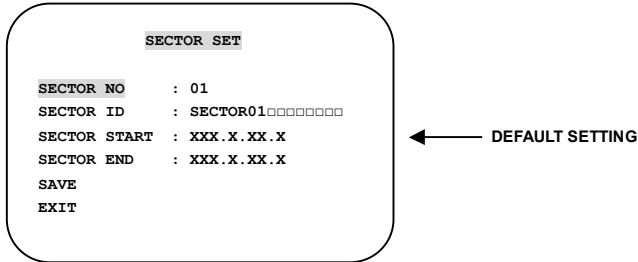

J-1. SECTOR SET - SECTOR NO.

Up to 8 programmable sectors are available.

J-2. SECTOR SET - SECTOR ID

To set a SECTOR ID, use the joystick or pan left/right keys.

Press **ZOOM TELE** button to move to the next character from left to right and

ZOOM WIDE button to move to the next character from right to left

(Space displays when □ appears)

J-3. SECTOR SET - SECTOR START

To set a SECTOR START position, press **FOCUS FAR** button then move the joystick

Or pan keys to set the position. Press **FOCUS FAR** button again to escape.

J-4. SECTOR SET - SECTOR END

To set a SECTOR END position, press **FOCUS FAR** button then move the joystick or

Pan keys to set the position. To press **FOCUS FAR** button again to escape.

J-5. SECTOR SET - SAVE

After setting the SECTOR positions, to save the data move the joystick right or press

the pan right key when the cursor is on SAVE. After saving the data, the cursor moves to SECTOR NO.2 automatically to prepare for the next SECTOR.

J-6. SECTOR SET - EXIT

To escape this page, move the joystick right or press the pan right key.

K. EXIT

To escape OSD Main Menu, move joystick to the right or left direction then this camera is ready to operate.

DIP SWITCH SETTING

A. ID SETTING

The camera has camera ID to be controlled by Controller or DVR.

After opening, set ID using DIP SW 1.

- Factory default : Camera ID = 1

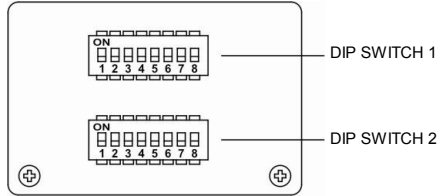

* (1-ON, 0-OFF)

DIP SW	VALOR ID	DIP SW	VALOR ID	DIP SW	VALOR ID
10000000	1	00010100	40	11110010	79
01000000	2	10010100	41	00001010	80
11000000	3	01010100	42	10001010	81
00100000	4	11010100	43	01001010	82
10100000	5	00110100	44	11001010	83
01100000	6	10110100	45	00101010	84
11100000	7	01110100	46	10101010	85
00010000	8	11110100	47	01101010	86
10010000	9	00001100	48	11101010	87
01010000	10	10001100	49	00011010	88
11010000	11	01001100	50	10011010	89
00110000	12	11001100	51	01011010	90
10110000	13	00101100	52	11011010	91
01110000	14	10101100	53	00111010	92
11110000	15	01101100	54	10111010	93
00001000	16	11101100	55	01111010	94
10001000	17	00011100	56	11111010	95
01001000	18	10011100	57	00000110	96
11001000	19	01011100	58	10000110	97
00101000	20	11011100	59	01000110	98
10101000	21	00111100	60	11000110	99
01101000	22	10111100	61	00100110	100
11101000	23	01111100	62	10100110	101
00011000	24	11111100	63	01100110	102
10011000	25	00000010	64	11100110	103
01011000	26	10000010	65	00010110	104
11011000	27	01000010	66	10010110	105
00111000	28	11000010	67	01010110	106
10111000	29	00100010	68	11010110	107
01111000	30	10100010	69	00110110	108
11111000	31	01100010	70	10110110	109
00000100	32	11100010	71	01110110	110
10000100	33	00010010	72	11110110	111
01000100	34	10010010	73	00001110	112
11000100	35	01010010	74	10001110	113
00100100	36	11010010	75	01001110	114
10100100	37	00110010	76	11001110	115
01100100	38	10110010	77	00111110	116
11100100	39	01110010	78	10111110	117

DIP SWITCH SETTING

DIP SW	VALOR ID	DIP SW	VALOR ID	DIP SW	VALOR ID
01101110	118	00100101	164	01001011	210
11101110	119	10100101	165	11001011	211
00011110	120	01100101	166	00101011	212
10011110	121	11100101	167	10101011	213
01011110	122	00010101	168	01101011	214
11011110	123	10010101	169	11101011	215
00111110	124	01010101	170	00011011	216
10111110	125	11010101	171	10011011	217
01111110	126	00101010	172	01011011	218
11111110	127	10110101	173	11011011	219
00000001	128	01110101	174	00111011	220
10000001	129	11110101	175	10111011	221
01000001	130	00001101	176	01111011	222
11000001	131	10001101	177	11111011	223
00100001	132	01001101	178	00000111	224
10100001	133	11001101	179	10000111	225
01100001	134	00101101	180	01000111	226
11100001	135	10101101	181	11000111	227
00010001	136	01101101	182	00100111	228
10010001	137	11101101	183	10100111	229
01010001	138	00011101	184	01100111	230
11010001	139	10011101	185	11100111	231
00110001	140	01011101	186	00010111	232
10110001	141	11011101	187	10010111	233
01110001	142	00111101	188	01010111	234
11110001	143	10111101	189	11010111	235
00001001	144	01111101	190	00110111	236
10001001	145	11111101	191	10110111	237
01001001	146	00000011	192	01110111	238
11001001	147	10000011	193	11110111	239
00101001	148	01000011	194	00001111	240
10101001	149	11000011	195	10001111	241
01101001	150	00100011	196	01001111	242
11101001	151	10100011	197	11001111	243
00011001	152	01100011	198	00101111	244
10011001	153	11100011	199	10101111	245
01011001	154	00010011	200	01101111	246
11011001	155	10010011	201	11101111	247
00111001	156	01010011	202	00011111	248
10111001	157	11010011	203	10011111	249
01111001	158	00110011	204	01011111	250
11111001	159	10110011	205	11011111	251
00000101	160	01110011	206	00111111	252
10000101	161	11110011	207	10111111	253
01000101	162	00001011	208	01111111	254
11000101	163	10001011	209	11111111	255

DIP SWITCH SETTING

B. 485 TERMINATION

The 1st of DIP SW2 is used for 100W termination.

Set ON DIP SW2 -1st of only the last looped camera from the controller.

Even in case of only one camera, set ON DIP SW2 -1st of the camera.

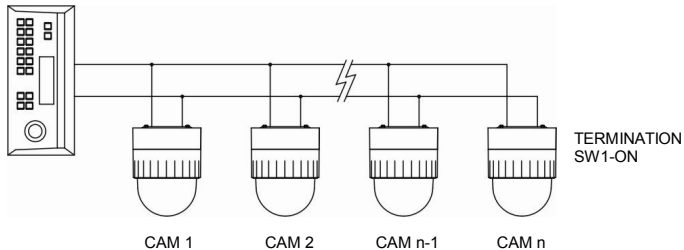

C. PROTOCOL

The 3rd, 4th of DIP SW2 above are used for Protocol Setting.

Factory default: Pelco-D or Pelco-P (Auto detection)

DIP SW 2-3 rd 4 th	
OFF/OFF	Pelco-D or Pelco-P
ON/ON	Not used
ON/OFF	Maxpro

D. BAUD RATE SETTING

The 7th, 8th SW of DIP SW2 above are used for BAUD RATE setting.

DIP SW can be changeable to 4800bps, 9600bps.

Factory default : 2400bps.

* PELCO D 2400bps

* PELCO P 4800bps

* MAXPRO 9600bps

DIP SW 2-7 th	DIP SW 2-8 th	BAUD RATE
OFF	OFF	Not Used
OFF	ON	2400bps
ON	OFF	4800bps
ON	ON	9600bps

* The 2nd, 4th, 5th, 6th of DIP SW2 are not used.

TROUBLE SHOOTING

If you have trouble operating in your camera, refer to the following.

PROBLEM	SOLUTION
No operating	<ul style="list-style-type: none">• Check if the power supply is AC24V.• Check if RS-485 communication cable is connected correctly.• Check camera ID setting.• Check the termination.
No picture	<ul style="list-style-type: none">• Check if all the cables are connected correctly.• Check the monitor is adjusted correctly.• Check if video signal line is cut.
Dark screen	<ul style="list-style-type: none">• Adjust the monitor status.
Abnormal camera operation status	<ul style="list-style-type: none">• Check if the voltage level is out of the specification.• Check the termination.
Screen not clear	<ul style="list-style-type: none">• Check if there is dust on a lens.• Adjust the monitor status.• If excessive light is seen on a screen, change the camera angle or location.• Adjust the lens focus again.

SPECIFICATION

MODEL		18X STC-3904/2	26X STC-3902/2	36X STC-3905/2	
PAN/TILT	Pan Rotation Angle		360° Endless		
	Pan Speed	Manual	0.5° ~ 100, 200° /sec (64step)		
		Preset	Max 300°/sec , Min 10°/sec		
	Tilt Rotation Angle		0° ~ 90°		
	Tilt Speed	Manual	0.5° ~ 100,200°/sec (64step)		
		Preset	Max 300°/sec , Min 10°/sec		
System Accuracy		0.024°			
FUNCTIONS	Presets		165 positions with 16-character label available for each position with different speed steps		
	Group Tour		Max. 8 Programmable group tours (each one consisting of up to 60 preset steps with different steps)		
	Auto scan		Programmable Auto scan		
	Pattern		8 Programmable Patterns (total 480 seconds)		
	Sector		8 selectable Sectors with 16 characters		
	Password Protection		Yes		
	Privacy Zone		24 privacy masking zones		
	Alarm Input		4 alarms(with various programmable states)		
	Alarm Actions		Activate preset, Group scanning or output per alarm input		
	Aux Output		2 Replay Output		
	Auto Flip		ON / OFF		
	OSD Menu		Yes		
	Communication		RS-485		
Protocol		Built in Pelco-D, Pelco-P, Maxpro			
POWER	Power Consumption		18W Max		
	Power Supply		18-32VAC 60/50Hz 850mA		
OTHERS	Construction		Cool Gray Body(ABS), Anti-vandal bubble (Poly Carbonate)		
	Dimensions		147Ø(D) * 190mm(H) (5.8"(D) * 7.5"(H))		
	Weight		1.9 kg (5 lbs)		
	Motor Type		Stepper		
	Micro Steps		1/8 Micro Step		
	Storage Temperature		20°C ~ 60°C (-4°F ~ 140°F)		
	Operating Temperature		-10°C ~ 50°C (14°F ~ 122°F)		
	Certifications		CE, FCC		
CAMERA MODULE	Image Sensor		1/4" Sony Exview HAD CCD		
	Total Image Pixels	NTSC	811(H) * 508(V)	410K	
		PAL	795(H) * 596(V)	470K	
	Number of Effective Pixels	NTSC	768(H) * 494(V)	380K	
		PAL	752(H) * 582(V)	440K	
	Horizontal resolution		More Than 480TV Lines		
	Lens	Optical	18x Optical Zoom (F=1.4~3.0, f=4.1~73.8mm)	26x Optical Zoom (F1.6~3.8, f=3.5~91.0mm)	36x Optical Zoom (F1.6~4.5, f=3.4~122.4mm)
		Digital	12x (216x with optical)	12x (312x with optical)	12x (432x with optical)
	Day & Night (ICR)		Auto / Day / Night		
	Min.Shooting Distance		0.29m(Wide) / 0.8m(Tele)	0.32m(Wide) / 1.5m(Tele)	0.32m(Wide) / 1.5m(Tele)
	Digital Slow Shutter		ON / OFF		
	Min. illumination	Normal mode	0.7Lux (50 IRE)	1.0Lux (50 IRE)	1.4Lux (50 IRE)
		Night mode	0.01Lux (ICR On)	0.01Lux (ICR On)	0.01Lux (ICR On)
	Luminance S/N Ratio		More than 50dB		
	Video Output		VBS:1.0Vp-p (sync negative), Y/C Output		
	BLC		ON / OFF		
	Flickerless		ON / OFF		

DIMENSIONS

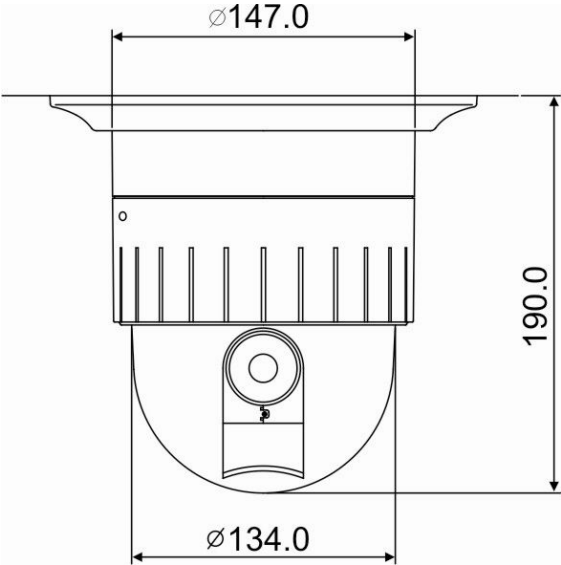

UNITS:mm