

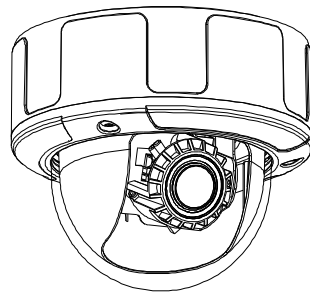

**1/3" D/N Color Vandal Proof Dome
Camera
Smartec STC-3502**



USER'S MANUAL

FEATURES

1. Lead (Pb) Free RoHS Compliance
2. Digital Signal Processor: SONY HQ1
3. Vandal proof and IP66 water proof level
4. Long life and high reliability are achieved by the use of a CCD image device.
5. Ease of use in any application is achieved.
6. Performance: More than 540 TV lines of resolution.
7. Lower power consumption.
8. Relatively no interference from magnetic or electrostatic field.
9. 3-axis structure design to freely rotate, tilt and pan to every angle.

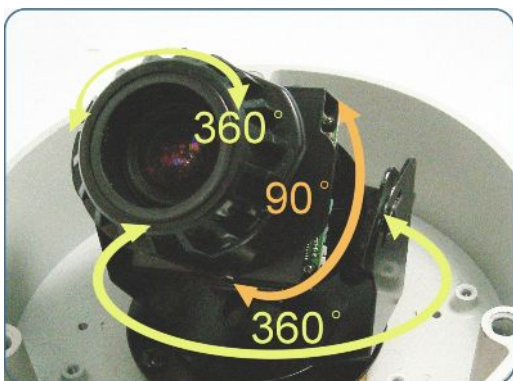

CAUTION

1. **Never point the camera toward the sun**

Do not expose the lens directly to the sun or to strong light as this may damage the pick-up device.

2. **Handle this camera with care**

Avoid any shock of the camera. Improper handling could damage the camera.

3. **Requires a proper operating environment**

This camera is designed for both indoor and out door use. The allowable temperature range for operation of this camera is between $-40^{\circ}\text{C} \sim +50^{\circ}\text{C}$ and the allowable humidity is 85% maximum.

4. **Check the power source voltage**

The power source voltage should be within the specified range. (Camera must meet the specification)

5. **Damage Requiring Service**

Unplug this video product from the wall outlet and refer service to qualified servicing personnel under the following conditions:

- a) When the power-supply cord or plug is damaged.
- b) If liquid has been spilled, or objects have fallen into the video product
- c) If the video product has been exposed to rain or water.
- d) If the cabinet has been damaged.
- e) When the video product exhibits a distinct change in performance.

SPECIFICATION

TV System	PAL	NTSC
Image Sensor	1/3" SONY Super HAD CCD	
DSP	SONY HQ1	
Number of Total Pixel	795(H)x596(V)	811(H)x508(V)
Synchronizing System	Internal	
Resolution	540TV Lines	
Minimum Illumination	0.05 Lux@F1.2	
	Color mode automatically switches to B/W mode under 2 Lux	
S/N Ratio	More than 48 dB (AGC OFF)	
Auto Gain Control	ON / OFF (switchable)	
Flickerless	ON / OFF (Switchable)	
BLC	ON / OFF (Switchable)	
Day & Night	Color / D/N (Switchable)	
DC Level	The VR for adjusting the IRIS level of auto Iris lens	
White Balance	AWB	
Video Output	1Vp-p composite / 75 Ω	
Lens / Angle of View	Standard: f2.9mm~10.0mm/F1.2 Aspherical Auto Iris lens/ 94.6°~28.8°	
Max Breaking Strength	656.1 Kgf	
Waterproof Level	IP66	
Heater	Built-in	
Power Supply	12Vdc/24Vac	
Power Consumption	Max: 7.2W	
Operating Temperature	-40°C ~ + 50° C	
Dimension	142 (DIA) X 112 (H)mm	
Weight	1070g	

DIMENSIONS (Unit: mm)

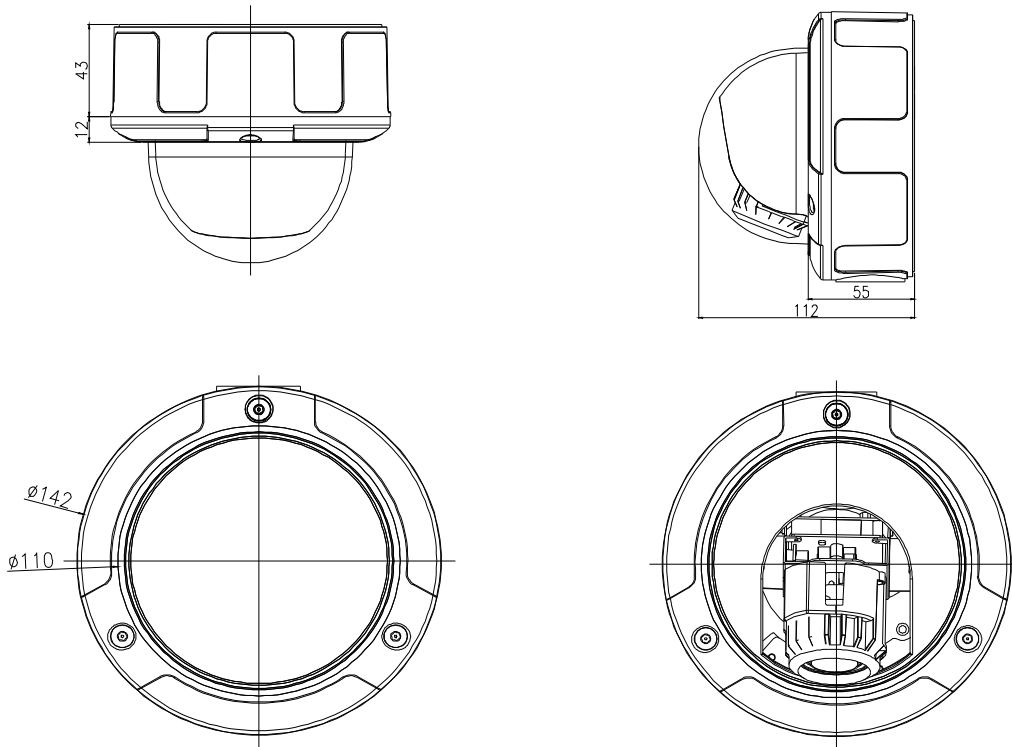

NOMENCLATURES AND FUNCTIONS

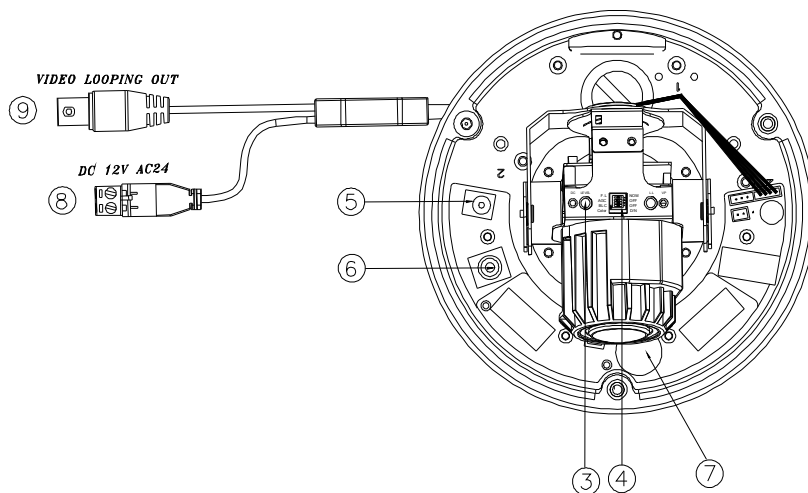
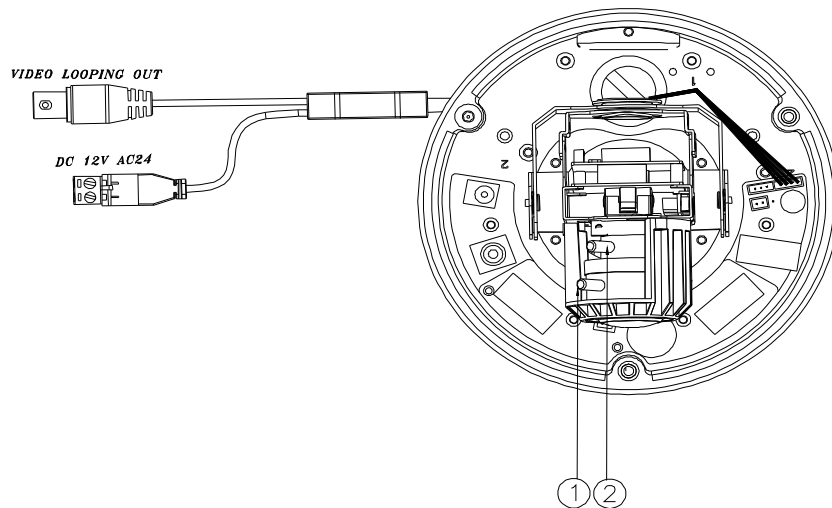

1. FAR/NEAR

2. WIDE/TELE

3. DC LEVEL

The VR for adjusting the IRIS level of Auto Iris lens.

4. CONTROL SWITCHES

Switch 1. D/N: Day & Night Switch

COLOR / D/N switch.

D/N: Color mode automatically switches to B/W mode under 2 Lux

COLOR: Normal position.

Switch 2. BLC: Backlight Compensation.

BLC / OFF switch.

When the object is dark by strong light (sunlight etc....) as (Fig.2-1), please turn on BLC to make object become bright as (Fig.2-2).

OFF: BLC OFF.

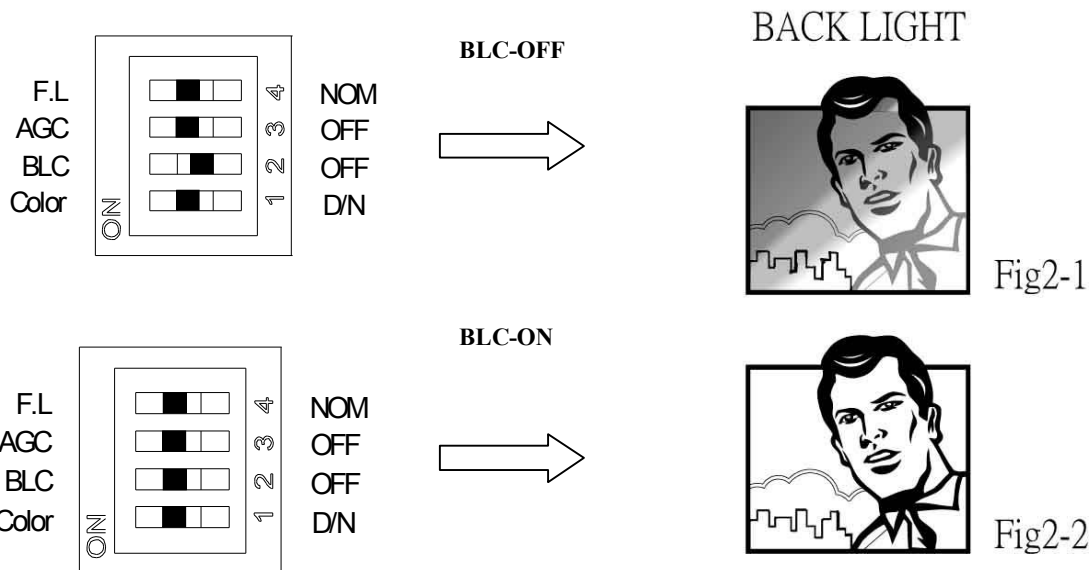

Switch 3. AGC: Automatic Gain Control.

AGC / OFF switch.

AGC level of gain varies from 0 to 26dB.

OFF: AGC OFF. The level of gain is fixed at 0dB.

Switch 4. FL: Flickerless.

F.L / NOM switch.

In FL mode, the shutter speed is 1/100sec. (NTSC system) / 1/120sec. (PAL).

If choose FL mode, [AES] switch should be off.

NOM: Normal position.

5. Secondary Power Input

This is a 12Vdc power input terminal for local testing.

6. Secondary Video Connector

This is a RCA video looping out for connection to a service monitor for local testing.

7. Heater

This heater will keep the lens and glass free of obscuring condensation. The built-in thermostat switches the heater on and off appropriately.

8. Power input terminal

Connect the power supply of 12Vdc/24Vac .

9. Video Output

This is an BNC video output for connection to a video monitor, etc (75Ω).

STANDARD INSTALLATION

To mount the camera directly on the ceiling:

- (1). Drill $\phi 25\text{mm}$ hole on the ceiling for video and power connector cable to pass through.

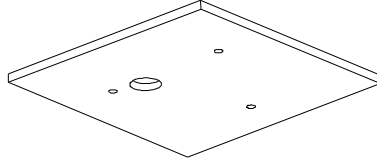

- (2). Take off the dome cover from the camera. Use specified holes inside the camera base for installation.

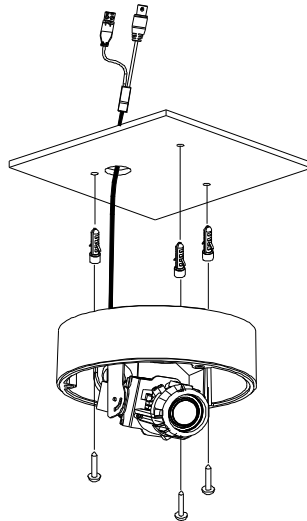

- (3). Fasten the camera base on the ceiling by using 3 screws provided.

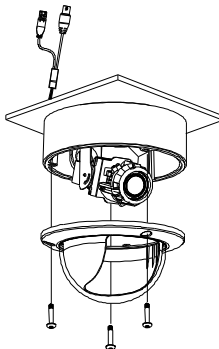

(4). Adjust pan/tilt/rotation until the image is satisfied. After adjustment of the camera, put the cover on.

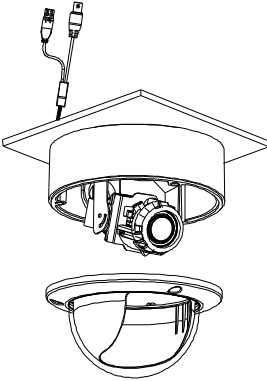

WATERPROOF INSTALLATION

(1). There are two conduit holes, one is at the dome bottom and the other one is at the side of camera with plug. Take off the dome cover and remove the plug from the side of the camera.

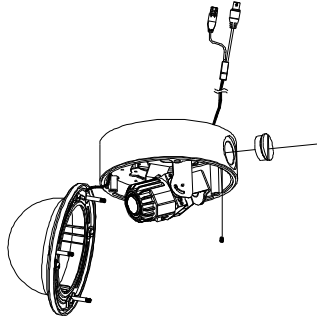

(2). Make the camera cables go through the conduit hole at the side of the camera. Put the plug into the conduit hole at the dome bottom. Then, fasten the camera base to the ceiling by using 3 screws provided.

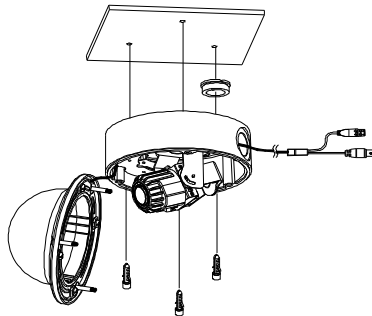

(3). Put the dome cover on and use 3 screws provided to fix it. Attach the metal conduit fittings(option) to the conduit hole and make the cables go through the connector.

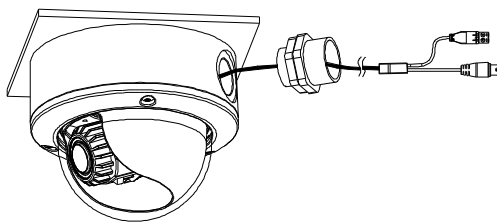

(4). Take a pipe and make the cables go through the pipe to avoid exposing the cables.

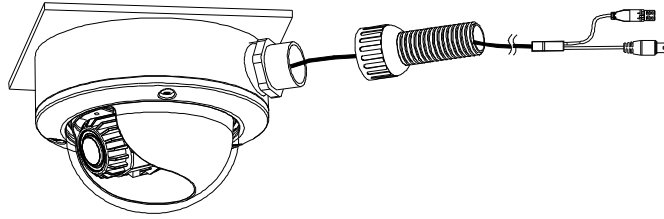

(5). Attach the pipe to the pipe connector and fasten it.

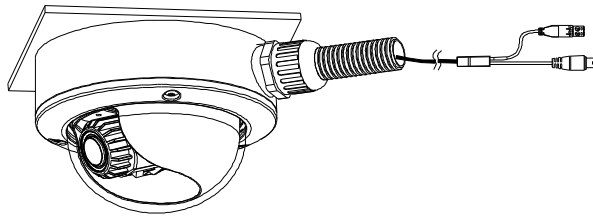

INSTALLATION WITH BRACKET

STB-C403 (WALL MOUNT INSTALLATION)

1. Fix the bracket on the wall by using 4 screws as shown in Figure 1.

Fig1.

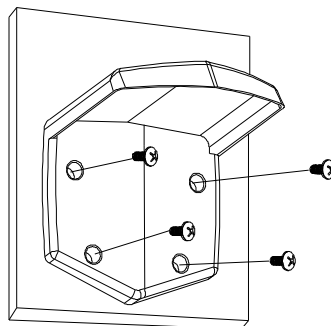

2. Fasten the metal plate on the top of the camera by 3 screws. (Fig2)

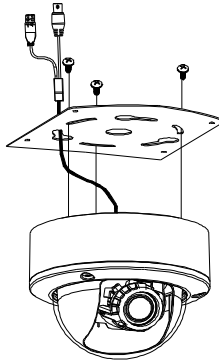

3. Use 4 screws to mount the camera to the bracket as shows in Figure 3.

Fig3.

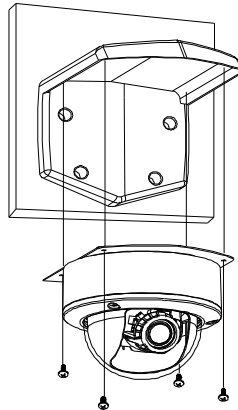

4. Then the wall mount installation is finished as Fig4.

Fig4.

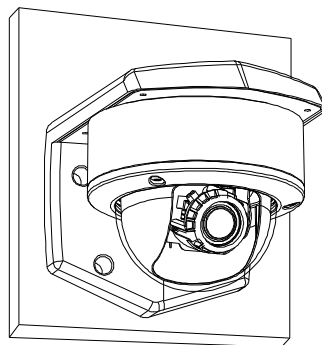

STB-C504 (CEILING MOUNT INSTALLATION)

1. Fix the base holder to the camera by 3 screws and 3 spacers as shown in Fig5.

Fig5.

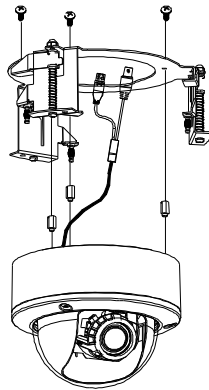

2. Use a screw driver (counter-clockwise) to fasten the base holder on ceiling ($\varnothing 184$) as Fig6 shows.

Fig6.

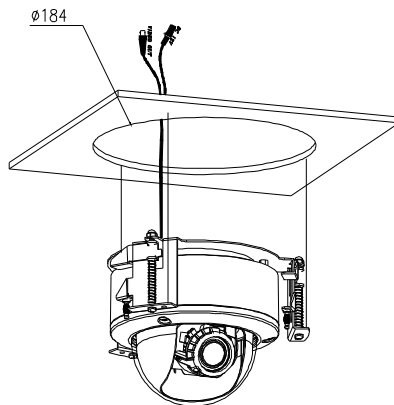

3. Put on the cover to the bracket on ceiling (Fig7).

Fig7.

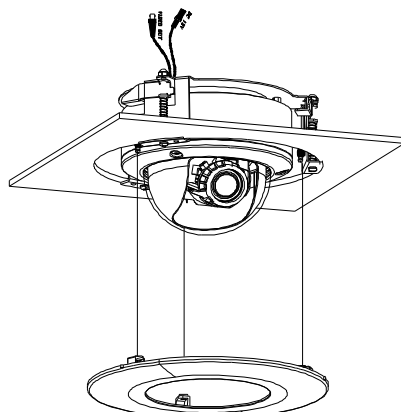

4. Then the ceiling mount installation is finished as Fig8.

Fig8.

